

The Most **Reliable**  
Storage For Industries

**PV25D-M242**



## Overview

### PV25D-M242

Apacer PV25D-M242 is a rugged, defense-grade PCIe solid-state drive in the M.2 2242 form factor, purpose-built for mission-critical defense applications that demand exceptional reliability and uncompromising data security. Supporting the high-speed PCIe Gen4 x4 interface and NVMe 1.4 specification, PV25D-M242 is powered by an advanced PCIe controller to deliver outstanding storage performance, reaching up to 560K/559K IOPS and sequential read/write speeds of up to 3325/3020 MB/s. Built with power-efficient 3D NAND flash and equipped with an LDPC (Low Density Parity Check) ECC engine, the drive ensures enhanced endurance and dependable data integrity for demanding operational environments.



To safeguard sensitive information, PV25D-M242 integrates advanced security technologies designed for defense systems. Hardware-based AES 256-bit encryption offloads encryption tasks to a dedicated processor, ensuring both strong protection and optimal system performance. In addition, MIL Erase and Instant Keychange enable rapid and secure data sanitization through software commands, providing robust protection for classified and mission-critical data.

PV25D-M242 is engineered with a comprehensive set of reliability technologies at both the hardware and firmware levels. On the hardware side, Apacer's Anti-Sulfuration technology employs specially selected alloy materials and protective processes compliant with the ANSI/ISA 71.04-2013 standard to enhance durability in harsh and contaminated environments. Additional protective measures, including Sidedfill, conformal coating, and 30 $\mu$  gold plating, further strengthen resistance to thermal and mechanical stress, ensuring stable operation in rugged defense and industrial deployments.

At the firmware level, PV25D-M242 incorporates intelligent thermal management through thermal throttling and a built-in thermal sensor, enabling real-time temperature monitoring via S.M.A.R.T. commands and dynamic frequency scaling to prevent overheating while maintaining stable performance. CoreGlacier™ technology further optimizes thermal efficiency to sustain high-speed operation under demanding workloads. For data integrity, End-to-End Data Protection safeguards data throughout the entire transfer path, while Smart Read Refresh™ prevents read disturbance and maintains NAND block health. Combined with Global Wear Leveling and DataDefender™, PV25D-M242 ensures stable data transmission and protection against unexpected power disruptions.

By integrating advanced hardware, firmware, and security technologies, Apacer PV25D-M242 delivers a highly resilient storage solution engineered for defense systems. Its robust architecture and comprehensive protection mechanisms ensure superior data security, integrity, and durability, making it an ideal choice for mission-critical applications operating in the most demanding environments.

## Features

- Rugged SSD PV25D Series
- Supports TCG Opal 2.0 / AES 256-bit Encryption
- NVMe Secure Erase
- S.M.A.R.T.
- SMART Read Refresh™
- Hyper Cache Technology
- Low-Density Parity-Check (LDPC) Code
- Thermal Sensor
- Thermal Throttling
- Over-Provisioning
- CoreGlacier™ heatsink technology
- Nano Coating / Conformal Coating / 30μ Gold Finger (Optional)

## Specifications

<b>Model Name</b>	PV25D-M242
<b>Interface</b>	PCIe Gen4 x4
<b>Connector</b>	Double-sided: M.2 2242 M key
<b>Form Factor</b>	M.2 2242
<b>NAND Flash Type</b>	3D TLC
<b>Capacity</b>	240GB-1920GB
<b>External DRAM</b>	No
<b>Sustained Read Performance (MB/sec.)</b>	Up to 3325
<b>Sustained Write Performance (MB/sec.)</b>	Up to 3020
<b>ECC Engine</b>	Low-Density Parity-Check (LDPC) Code
<b>IOPS (4K Random Write)</b>	559K
<b>Standard Operating Temperature ( °C )</b>	0 ~ 70
<b>Extended Operating Temperature ( °C )</b>	-40 ~ 85
<b>Storage Temperature ( °C )</b>	-55 ~ 100
<b>Housing</b>	-
<b>Thermal Sensor</b>	Yes
<b>Shock</b>	MIL-STD-202G, Condition A MIL-STD-883K, Condition B
<b>Vibration</b>	MIL-STD-810G, Method 514.6, Procedure I, Category 24 MIL-STD-810G, Method 514.6, Procedure I, Category 7
<b>Operating Voltage</b>	3.3V ± 5%
<b>Power Consumption</b>	Low Power PS4 (L1.2): < 5.5mW / Idle mode: 101 Ma
<b>Dimension (L x W x H )</b>	22.00 x 42.00 x 4.08mm (max.)
<b>MTBF (Hours)</b>	>5,000,000

## Mechanical Specifications

Top View

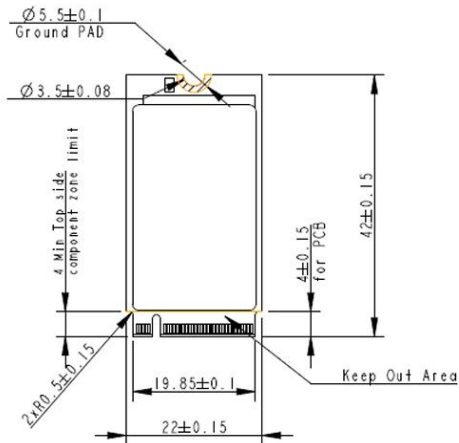

Bottom View

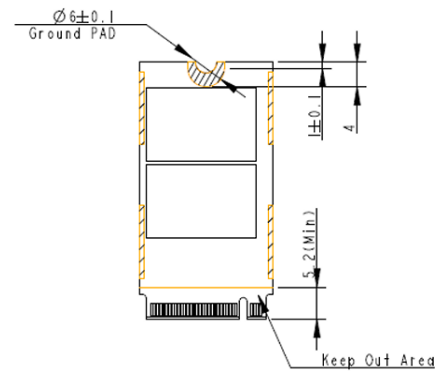
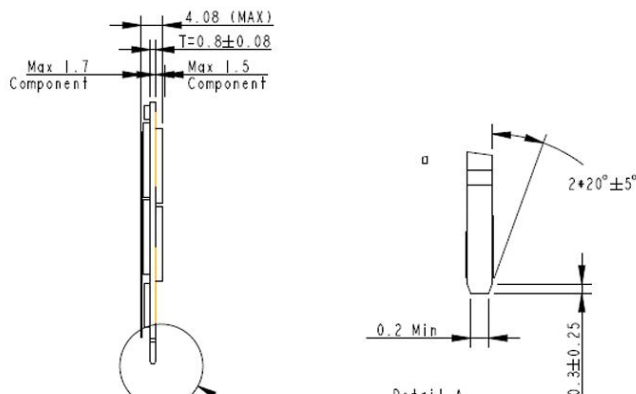

Figure 10-1 Physical Dimensions

Side View



**For more information,  
contact your Apacer representative**

### Global Presence

Taiwan (Headquarter)  
Apacer Technology Inc.  
Tel: +886-2-2267-8000

Europe  
Apacer Technology B.V.  
Tel: +31-40-267-0000

U.S.A.  
Apacer Memory America, Inc.  
Tel: +1-408-518-8699

China  
Apacer Electronic (Shanghai)  
Co., Ltd.  
Tel: +86-21-6228-9939

Japan  
Apacer Technology Corp.  
Tel: +81-3-5419-2668

India  
Apacer Technologies Pvt. Ltd.  
Tel: +91-80-35910296